



Model Number

NBB20-L2-A2-V1-3G-3D

Features

- Sensor head bidirectional and rotatable
- 20 mm flush
- 4-wire DC
- Quick mounting bracket
- 4-way LED indicator
- ATEX-approval for zone 2 and zone 22

Accessories

MHW 01

Modular mounting bracket

MH 02-L

Mounting aid

Technical Data

General specifications

Switching function		complementary
Output type		PNP
Rated operating distance	s_n	20 mm
Installation		flush
Output polarity		DC
Assured operating distance	s_a	0 ... 16.2 mm
Actual operating distance	s_r	18 ... 22 mm
Reduction factor r_{Al}		0.33
Reduction factor r_{Cu}		0.31
Reduction factor r_{304}		0.74
Reduction factor r_{Brass}		0.41
Output type		4-wire

Nominal ratings

Operating voltage	U_B	10 ... 30 V DC
Switching frequency	f	0 ... 150 Hz
Hysteresis	H	typ. 5 %
Reverse polarity protection		reverse polarity protected
Short-circuit protection		pulsing
Voltage drop	U_d	≤ 2 V
Design data		
Operating current	I_L	0 ... 200 mA
Off-state current	I_r	0 ... 0.5 mA
No-load supply current	I_0	≤ 20 mA
Time delay before availability	t_v	80 ms
Operating voltage indicator		LED, green
Switching state indicator		LED, yellow

Functional safety related parameters

MTTF _d	1239 a
Mission Time (T_M)	20 a
Diagnostic Coverage (DC)	0 %

Ambient conditions

Ambient temperature	-25 ... 85 °C (-13 ... 185 °F)
Storage temperature	-40 ... 85 °C (-40 ... 185 °F)

Mechanical specifications

Connection type	Connector plug M12 x 1, 4-pin
Housing material	PA
Sensing face	PA
Degree of protection	IP69K
Mass	130 g

General information

Use in the hazardous area	see instruction manuals
Category	3G; 3D

Compliance with standards and directives

Standard conformity	
Standards	EN 60947-5-2:2007 IEC 60947-5-2:2007

Approvals and certificates

Protection class	II
Rated insulation voltage	U_i 253 V
Rated impulse withstand voltage	U_{imp} 4000 V
UL approval	cULus Listed, General Purpose
CSA approval	cCSAus Listed, General Purpose
CCC approval	CCC approval / marking not required for products rated ≤ 36 V

Dimensions

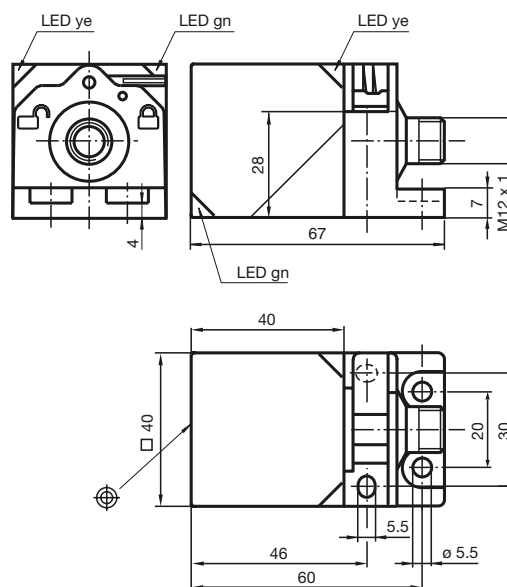

Electrical Connection

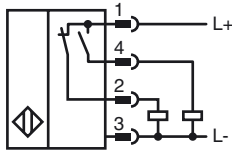

Pinout

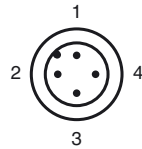

Wire colors in accordance with EN 60947-5-2

1	BN	(brown)
2	WH	(white)
3	BU	(blue)
4	BK	(black)

Equipment protection level Gc (nA)

Certificate	PF 15CERT3754 X
CE marking	CE
ATEX marking	Ex II 3G Ex nA IIC T6 Gc The Ex-related marking can also be printed on the enclosed label.
Standards	EN 60079-0:2012+A11:2013, EN 60079-15:2010 Ignition protection category "n" Use is restricted to the following stated conditions

Special conditions

Maximum operating current I_L	The maximum permissible load current must be restricted to the values given in the following list. High load currents and load short-circuits are not permitted.
Maximum operating voltage U_{Bmax}	The maximum permissible operating voltage U_{Bmax} is restricted to the values in the following list. Tolerances are not permissible.
Maximum permissible ambient temperature T_{Umax}	dependant of the load current I_L and the max. operating voltage U_{Bmax} Information can be taken from the following list.
at $U_{Bmax}=30\text{ V}$, $I_L=200\text{ mA}$	48 °C (118.4 °F)
at $U_{Bmax}=30\text{ V}$, $I_L=100\text{ mA}$	50 °C (122 °F)
at $U_{Bmax}=30\text{ V}$, $I_L=50\text{ mA}$	51 °C (123.8 °F)
at $U_{Bmax}=30\text{ V}$, $I_L=25\text{ mA}$	52 °C (125.6 °F)

Equipment protection level Dc

CE marking	CE
ATEX marking	Ex II 3D IP69K T 107 °C (224.6 °F) X The Ex-significant identification is on the enclosed adhesive label
Standards	EN 50281-1-1 Protection via housing Use is restricted to the following stated conditions

Special conditions

Maximum heating (Temperature rise)	dependant of the load current I_L and the max. operating voltage U_{Bmax} Information can be taken from the following list. The maximum surface temperature at maximum ambient temperature is given in the Ex identification of the apparatus.
at $U_{Bmax}=30\text{ V}$, $I_L=200\text{ mA}$	22 K
at $U_{Bmax}=30\text{ V}$, $I_L=100\text{ mA}$	19 K
at $U_{Bmax}=30\text{ V}$, $I_L=50\text{ mA}$	18 K
at $U_{Bmax}=30\text{ V}$, $I_L=25\text{ mA}$	17 K

Equipment protection level Dc (tc)

CE marking	CE
ATEX marking	Ex II 3D Ex tc IIIC T80°C Dc The Ex-related marking can also be printed on the enclosed label.

Release date: 2016-11-07 10:02 Date of issue: 2018-02-19 129869_eng.xml

Standards	EN 60079-0:2012+A11:2013, EN 60079-31:2014 Protection by enclosure "tc" Some of the information in this instruction manual is more specific than the information provided in the datasheet.
General	The corresponding datasheets, declarations of conformity, EC-type examination certificates, certifications, and control draw (see datasheets), form an integral part of this document. These documents can be found at www.pepperl-fuchs.com . The maximum surface temperature of the device was determined without a layer of dust of the information in this instruction manual is more specific than the information provided in the datasheet.
Special conditions	
Maximum permissible ambient temperature $T_{U_{max}}$	dependant of the load current I_L and the max. operating voltage $U_{B_{max}}$ Information can be taken from the following list.
at $U_{B_{max}}=30\text{ V}$, $I_L=200\text{ mA}$	48 °C (118.4 °F)
at $U_{B_{max}}=30\text{ V}$, $I_L=100\text{ mA}$	50 °C (122 °F)
at $U_{B_{max}}=30\text{ V}$, $I_L=50\text{ mA}$	51 °C (123.8 °F)
at $U_{B_{max}}=30\text{ V}$, $I_L=25\text{ mA}$	52 °C (125.6 °F)
Equipment protection level Dc (tD)	
General	The apparatus has to be operated according to the appropriate data in the data sheet and in this instruction manual. The maximum surface temperature has been determined in accordance with method A without a dust layer on the equipment. The data stated in the data sheet are restricted by this operating instruction! The special conditions must be adhered to!
Special conditions	
Maximum permissible ambient temperature $T_{U_{max}}$	dependant of the load current I_L and the max. operating voltage $U_{B_{max}}$ Information can be taken from the following list.
at $U_{B_{max}}=30\text{ V}$, $I_L=200\text{ mA}$	48 °C (118.4 °F)
at $U_{B_{max}}=30\text{ V}$, $I_L=100\text{ mA}$	50 °C (122 °F)
at $U_{B_{max}}=30\text{ V}$, $I_L=50\text{ mA}$	51 °C (123.8 °F)
at $U_{B_{max}}=30\text{ V}$, $I_L=25\text{ mA}$	52 °C (125.6 °F)